

# Emergency Exit Sign Lighting



## Version „OMEGA“



### Emergency Exit Sign Lighting Version „OMEGA“

**Pendant suspension lamp  
Single battery supply**

**Recognition distance:**

- 20 m
- 30 m

### Specification

Version	OMEGA
Recognition distance	20 m / 30 m
Mounting	Pendant suspended
Light source	2 x 3 W LED
Power	230V single battery system 10,0 VA
Battery	NiMH 3,6 V / 700 mA, service life rating 3,0 h
Ambient temperature	-10 °C - +40 °C
IP class	IP 30
Protection class	I
Housing	Aluminium profile, steel sheet coloured
Weight	ca. 1,1 kg / 1,4 kg
Pendulum	500 mm chrome-plated
Dimension (l x w x h) (20 m/30 m)	133 x 216 x 78 mm / 193 x 316 x 84 mm
Pictogram	Pictogram set according to DIN 4844 ( ← / ↓ / → )
Luminance	Limit of luminance of 500 cd/m <sup>2</sup> according to DIN 4844-1 is clearly exceeded in mains operation. The luminance in emergency operation is higher than required by DIN EN 1838.
Terminal	Cable end of pendant suspension to connect with lighting connector

### Order information

		X=Standard: Alu natural	Special colour: Y=RAL colour
<b>Single battery system Lamp self-contained</b>	20 m	<b>711280 - OM/E/20/X/P/S/LU</b>	<b>711180 - OM/E/20/Y /P/S/LU</b>
	30 m	<b>712280 - OM/E/30/X/P/S/LU</b>	<b>712180 - OM/E/30/Y /P/S/LU</b>
<b>Single battery system Lamp with 2 wire bus system</b>	20 m	<b>711480 - OM/E/20/X/P/C/LU</b>	<b>711380 - OM/E/20/Y/P/C/LU</b>
	30 m	<b>712480 - OM/E/30/X/P/C/LU</b>	<b>712380 - OM/E/30/Z/P/C/LU</b>

## Dimension

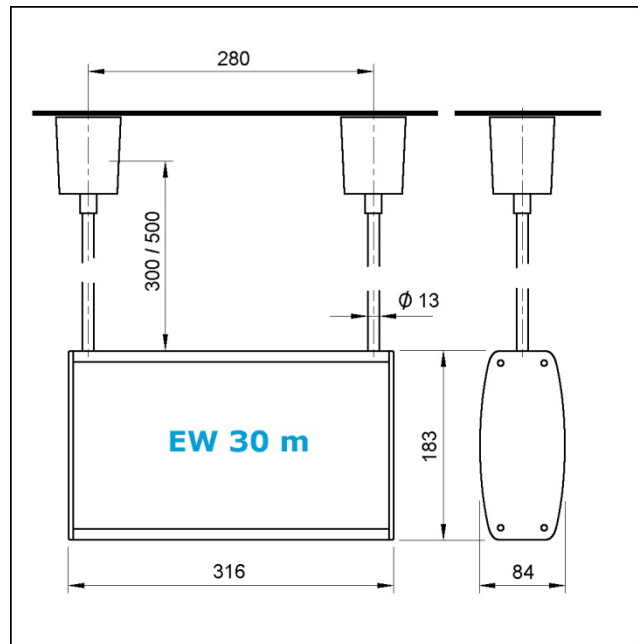
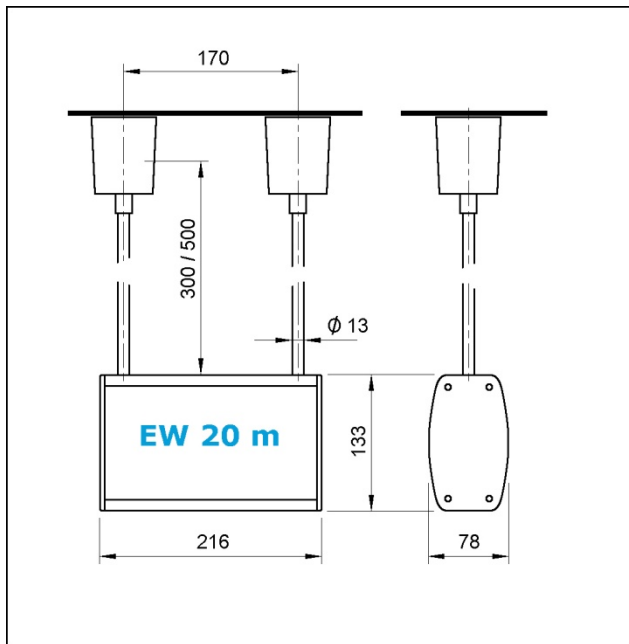

## Display mode – Indicator LED

Handling push button	Mode of indicator LED	Meaning	Troubleshooting
	Green LED on	Charging function is running	
	Green LED off	No charge (battery is missing)	→Connect battery
Keep push button pressed until green LED flashes (longer interval)	Green LED flashes ( longer interval)	Verify function – functional test is running	
Keep push button pressed until green LED flashes (short interval)	Green LED flashes ( short interval)	Verify function – capacity test is running	
Keep push button pressed at capacity test	Green LED flashes ( short interval)	Stop capacity test	
	Green LED short flashes	Status check of monitoring system is running	
	Red LED on	Defect of lighting source	→Exchange defect lighting source (LED)
	Red LED off	No fault	
	Red LED flashes ( longer interval)	Battery defect	→ Charge battery for 14 h at least or exchange battery
	Red LED flashes ( short interval)	Battery test is required after 1 year	→ Press push button until green LED flashes (short interval)

## Installation

See document „Installation instruction Emergency exit sign lighting version OMEGA“

### Forchheim und Willing GmbH

Südstraße 21  
09221 Neukirchen / Erzgebirge - Germany

Phone: 0049 371 27816-0  
Fax: 0049 371 27816-29  
E-Mail: info@forchheim-willing.de  
Internet: www.forchheim-willing.de