

Emergency Exit Sign Lighting

Version „SIGMA“



Emergency Exit Sign Lighting Version „SIGMA“

Surface mounted lamp
Single battery system

Recognition distance:

- 20 m
- 30 m

Specification

Version	SIGMA
Recognition distance	20 m / 30 m
Mounting	Surface mounted
Light source	5 x 0,4 W LED / 10 x 0,4 W LED
Power	230 V single battery system 7,0 VA / 13,0 VA
Battery	NiMH 3,6 V / 700 mA, service life rating 3,0 h
Ambient temperature	-10 °C - +40 °C
IP class	IP 40
Protection class	I
Housing	Aluminium profile, steel sheet coloured
Weight	ca. 0,9 kg / 1,1 kg
Dimension (l x w x h) (20 m/30 m)	230 x 246 x 75 mm / 280 x 346 x 75 mm
Pictogram	Pictogram set according to DIN 4844 (← / ↓ / →)
Luminance	Limit of luminance of 500 cd/m ² according to DIN 4844-1 is clearly exceeded in mains operation. The luminance in emergency operation is higher than required by DIN EN 1838.
Terminal	WAGO Lighting connector 2,5 mm ²
Special option	Special pictograms optionally

Order information

		X = Standard: Alu natural	Special colour: Y = RAL colour
Single battery system Lamp self-contained	20 m	731110 - SI/E/20/X/D/S	731310 - SI/E/20/Y/D/S
	30 m	732110 - SI/E/30/X/D/S	732310 - SI/E/30/Z/Y/S
Single battery system Lamp with 2 wire bus system	20 m	731210 - SI/E/20/X/D/C	731410 - SI/E/20/Y/D/C
	30 m	732410 - SI/E/30/X/D/C	732610 - SI/E/30/Y/D/C

Dimension

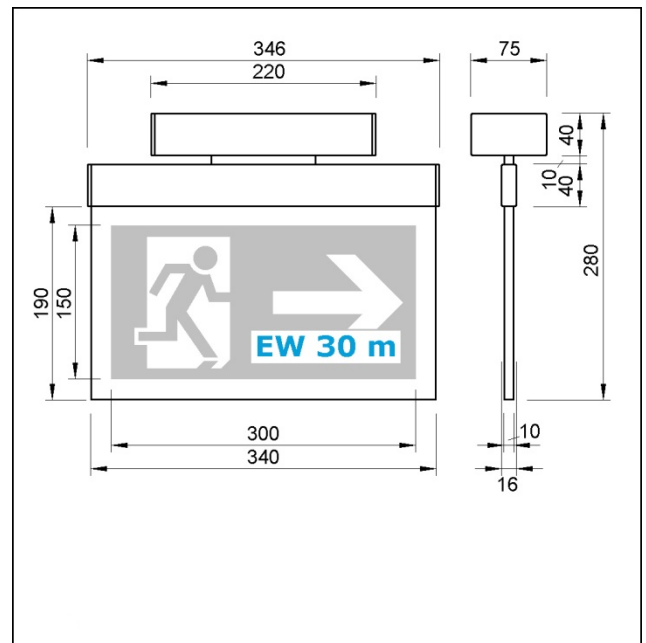
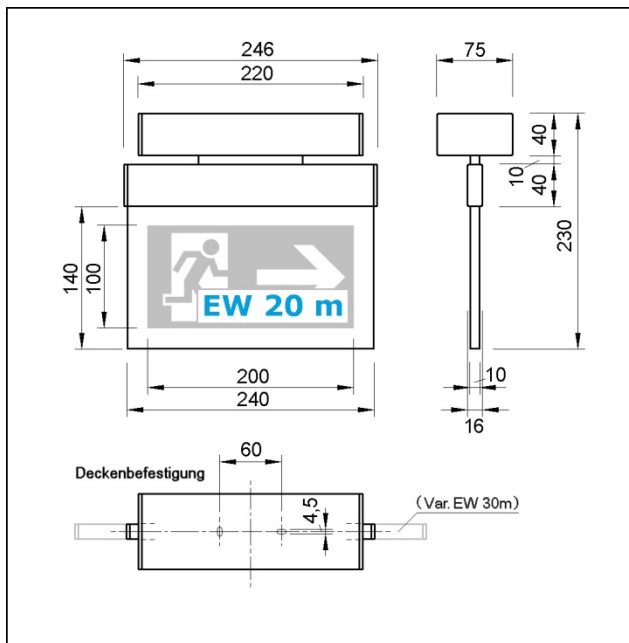

Display mode – Indicator LED

Handling push button	Mode of indicator LED	Meaning	Troubleshooting
	Green LED on	Charging function is running	
	Green LED off	No charge (battery is missing)	→Connect battery
Keep push button pressed until green LED flashes (longer interval)	Green LED flashes (longer interval)	Verify function – functional test is running	
Keep push button pressed until green LED flashes (short interval)	Green LED flashes (short interval)	Verify function – capacity test is running	
Keep push button pressed at capacity test	Green LED flashes (short interval)	Stop capacity test	
	Green LED short flashes	Status check of monitoring system is running	
	Red LED on	Defect of lighting source	→Exchange defect lighting source (LED)
	Red LED off	No fault	
	Red LED flashes (longer interval)	Battery defect	→ Charge battery for 14 h at least or exchange battery
	Red LED flashes (short interval)	Battery test is required after 1 year	→ Press push button until green LED flashes (short interval)

Montage Installation

See document „Installation instruction Emergency exit sign lighting version SIGMA“

Forchheim und Willing GmbH

Südstraße 21
09221 Neukirchen / Erzgebirge - Germany

Phone: 0049 371 27816-0
Fax: 0049 371 27816-29
E-Mail: info@forchheim-willing.de
Internet: www.forchheim-willing.de