

# Emergency Exit Sign Lighting



## Vesion „SIGMA“



### Emergency Exit Sign Lighting Version „SIGMA“

**Pendant suspension lamp  
Single battery system**

Recognition distance:

- 20 m
- 30 m

### Specification

Version	SIGMA
Recognition distance	20 m / 30 m
Mounting	Pendant suspended
Light source	5 x 0,4 W LED / 10 x 0,4 W LED
Power	230V single battery system 7,0 VA / 13,0 VA
Battery	NiMH 3,6 V / 700 mA, service life rating 3,0 h
Ambient temperature	-10 °C - +40 °C
IP class	IP 40
Protection class	I
Housing	Aluminium profile, steel sheet coloured
Weight	ca. 0,9 kg / 1,1 kg
Dimension (l x w x h) (20 m/30 m)	720 x 246 x 75 mm / 770 x 346 x 75 mm
Luminance	Standard pendulum length max. 500 mm 500 mm Limit of luminance of 500 cd/m <sup>2</sup> according to DIN 4844-1 is clearly exceeded in mains operation. The luminance in emergency operation is higher than required by DIN EN 1838.
Terminal	WAGO Lighting connector 2,5 mm <sup>2</sup>
Special option	Special pictograms optionally

### Order information

		X = Standard: Alu antural	Special colour: Y = RAL colour
<b>Single battery system Lamp self-contained</b>	20 m	<b>731130 - SI/E/20/X/P/S</b>	<b>731330 - SI/E/20/Y/P/S</b>
	30 m	<b>732130 - SI/E/30/X/P/S</b>	<b>732330 - SI/E/30/Y/P/S</b>
<b>Single battery system Lamp with 2 wire bus system</b>	20 m	<b>731230 - SI/E/20/X/P/C</b>	<b>731430 - SI/E/20/Y/P/C</b>
	30 m	<b>732430 - SI/E/30/X/P/C</b>	<b>732630 - SI/E/30/Y/P/C</b>

## Dimension

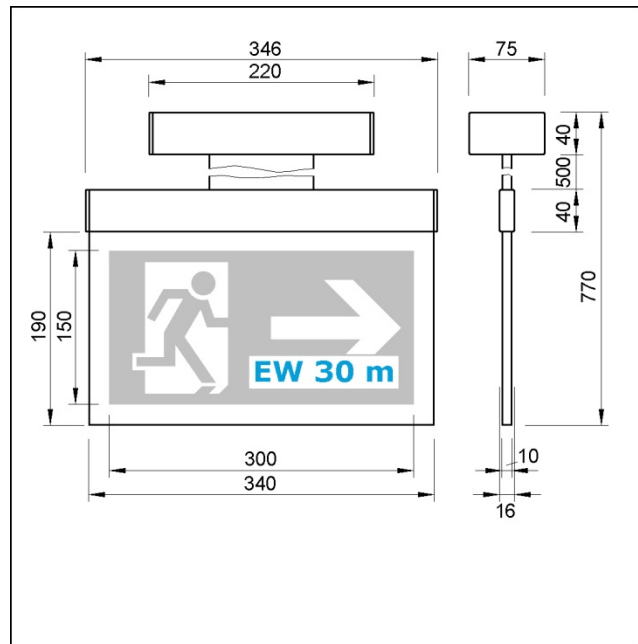
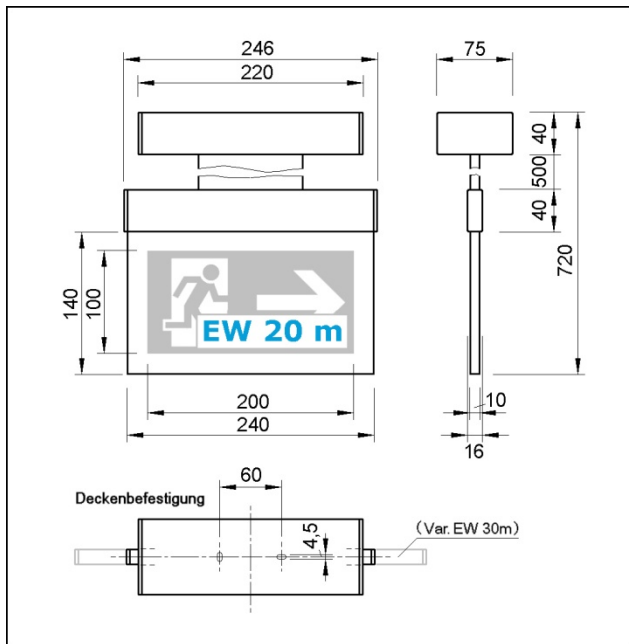

## Display mode – Indicator LED

Handling push button	Mode of indicator LED	Meaning	Troubleshooting
	Green LED on	Charging function is running	
	Green LED off	No charge (battery is missing)	→Connect battery
Keep push button pressed until green LED flashes (longer interval)	Green LED flashes ( longer interval)	Verify function – functional test is running	
Keep push button pressed until green LED flashes (short interval)	Green LED flashes ( short interval)	Verify function – capacity test is running	
Keep push button pressed at capacity test	Green LED flashes ( short interval)	Stop capacity test	
	Green LED short flashes	Status check of monitoring system is running	
	Red LED on	Defect of lighting source	→Exchange defect lighting source (LED)
	Red LED off	No fault	
	Red LED flashes ( longer interval)	Battery defect	→ Charge battery for 14 h at least or exchange battery
	Red LED flashes ( short interval)	Battery test is required after 1 year	→ Press push button until green LED flashes (short interval)

## Montage

See document „Installation instruction Emergency exit sign lighting version SIGMA“

### Forchheim und Willing GmbH

Südstraße 21  
09221 Neukirchen / Erzgebirge - Germany

Phone: 0049 371 27816-0  
Fax: 0049 371 27816-29  
E-Mail: info@forchheim-willing.de  
Internet: www.forchheim-willing.de