

Emergency Exit Sign Lighting



Version „SIGMA“



Emergency Exit Sign Lighting Version „SIGMA“

Surface mounted lamp /
cable suspended
Single battery system

Recognition distance:

- 20 m
- 30 m

Specification

| | |
|-----------------------|---|
| Version | SIGMA |
| Recognition distance | 20 m / 30 m |
| Mounting | Surface mounted, cable suspended |
| Light source | 5x0,4W LED / 10x0,4W LED |
| Power | 230V single battery 7,0 VA / 13,0 VA |
| Battery | NIMH 3,6V / 700mA, service life rating 3,0 h |
| Ambient temperature | -10 + 40°C |
| IP class | IP 40 |
| Protection class | I for 230V |
| Housing | Aluminium profile, steel sheet coloured |
| Weight | ca. 0,9 kg / 1,1Kg |
| Dimension (l x w x h) | 230 x 246 x 75 mm / 280 x 346 x 75 mm |
| Pictogram | Pictogram set according to DIN 4844 (← / ↓ / →) |
| Luminance | Limit of luminance of 500 cd/m ² according to DIN 4844-1 is clearly exceeded in mains operation. The luminance in emergency operation is higher than required by DIN EN 1838. |
| Terminal | WAGO Lighting connector 2,5 mm ² |
| Special option | Special pictograms optionally |

Order information

| | | X = Standard: Alu natural | Special colour: Y = RAL colour |
|--|-----|-------------------------------|--------------------------------|
| Single battery system Lamp self-contained | 20m | 731316 - SI/E/20/X/S/S | SI/E/20/Z/S/S |
| | 30m | 732116 - SI/E/30/X/S/S | SI/E/30/Z/S/S |
| Single battery system Lamp with 2 wire bus system | 20m | 731416 - SI/E/20/X/S/C | SI/E/20/Z/S/C |
| | 30m | 732116 - SI/E/30/X/S/C | SI/E/30/Z/S/C |

Dimension

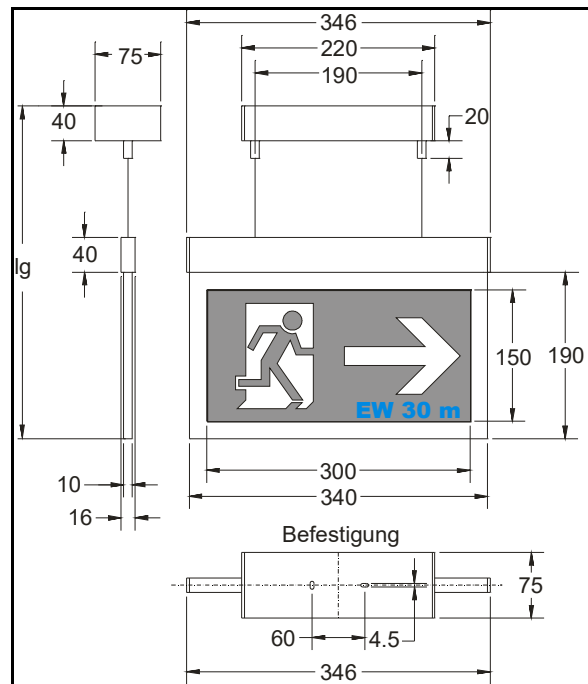
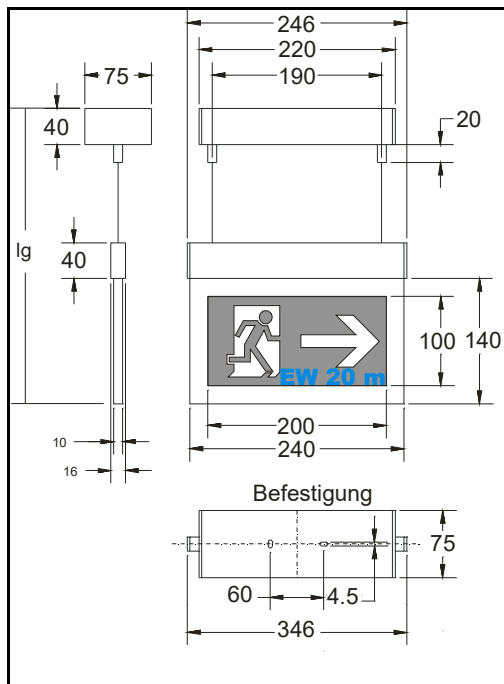

Display mode – Indicator LED

| Handling push button | Mode of indicator LED | Meaning | Troubleshooting |
|--|--------------------------------------|--|--|
| | Green LED on | Charging function is running | |
| | Green LED off | No charge (battery is missing) | →Connect battery |
| Keep push button pressed until green LED flashes (longer interval) | Green LED flashes (longer interval) | Verify function – functional test is running | |
| Keep push button pressed until green LED flashes (short interval) | Green LED flashes (short interval) | Verify function – capacity test is running | |
| Keep push button pressed at capacity test | Green LED flashes (short interval) | Stop capacity test | |
| | Green LED short flashes | Status check of monitoring system is running | |
| | Red LED on | Defect of lighting source | →Exchange defect lighting source (LED) |
| | Red LED off | No fault | |
| | Red LED flashes (longer interval) | Battery defect | → Charge battery for 14 h at least or exchange battery |
| | Red LED flashes (short interval) | Battery test is required after 1 year | → Press push button until green LED flashes (short interval) |

Installation

See document „Installation instruction Emergency exit sign lighting version SIGMA“

Forchheim und Willing GmbH

Südstraße 21
09221 Neukirchen / Erzgebirge - Germany

Phone: 0049 371 27816-0
Fax: 0049 371 27816-29
E-Mail: info@forchheim-willing.de
Internet: www.forchheim-willing.de